

**Part Number: PW301-10001**

**Kit Contents** (see next page for description)

Item #	Quantity Req.	Description
1	1	Front cross bar
2	1	Rear cross bar
3	2	Cross bar rubber trim
4	2	Key
5	4	Insert
6	1	Front Right Cover
7	1	Front Left Cover
8	1	Rear Right Cover
9	1	Rear Left Cover
10	1	Front Right Pad
11	1	Front Left Pad
12	1	Rear Right Pad
13	1	Rear Left Pad
14	1	Installation Torque Tool
15	1	Installation Instructions

**Hardware Bag Contents**

Item #	Quantity Req.	Description

**Additional Items Required For Installation**

Item #	Quantity Req.	Description

**Conflicts**

None
------

**Recommended Tools**

<b>Personal &amp; Vehicle Protection</b>	<b>Notes</b>
Blanket	Protect the roof
<b>Special Tools</b>	<b>Notes</b>
<b>Installation Tools</b>	<b>Notes</b>
Scissors	
Tape Measure	Metric
Nylon Panel Removal Tool	e.g. Panel Pry Tool #1 Toyota SST# 00002-06001-01
Plier	
<b>Special Chemicals</b>	<b>Notes</b>
Cleaner	VDC Approved Surface Cleaner
Soap & Water Solution	DIO Installations

**General Applicability**

MY18 and newer standard C-HR models
-------------------------------------

**Recommended Sequence of Application**

Item #	Accessory
1	
2	
3	

\*Mandatory

**Vehicle Service Parts** (may be required for reassembly)

Item #	Quantity Req.	Description
1		
2		
3		

**Legend**

 **STOP:** Damage to the vehicle may occur. Do not proceed until process has been complied with.

 **OPERATOR SAFETY:** Use caution to avoid risk of injury.

 **CAUTION:** A process that must be carefully observed in order to reduce the risk of damage to the accessory/vehicle and to ensure a quality installation.

 **TOOLS & EQUIPMENT:** Used in Figures calls out the specific tools and equipment recommended for this process.

 **REVISION MARK:** This mark highlights a change in installation with respect to previous issue.

 **SAFETY TORQUE:** This mark indicates that torque is related to safety.

Care must be taken when installing this accessory to ensure damage does not occur to the vehicle. The installation of this accessory should follow approved guidelines to ensure a quality installation.

These guidelines can be found in the "Accessory Installation Practices" document.

This document covers such items as:-

- Vehicle Protection (use of covers and blankets, cleaning chemicals, etc.).
- Safety (eye protection, rechecking torque procedure, etc.).
- Vehicle Disassembly/Reassembly (panel removal, part storage, etc.).
- Electrical Component Disassembly/Reassembly (battery disconnection, connector removal, etc.).

Please see your Toyota dealer for a copy of this document.

**1. Check the Kit & Warnings**

(a) Verify the kit contents (Fig. 1-1).

- (1) A1 = Front cross bar (1 pc)
- (2) A2 = Rear cross bar (1 pc)
- (3) B = Covers (4 pcs) & keys (2 pcs)
- (4) C = Rubber pads (4 pcs)
- (5) D = Insert (4 pcs)
- (6) E = Installation tool (1 pc)
- (7) F = Rubber strip (2 pcs)

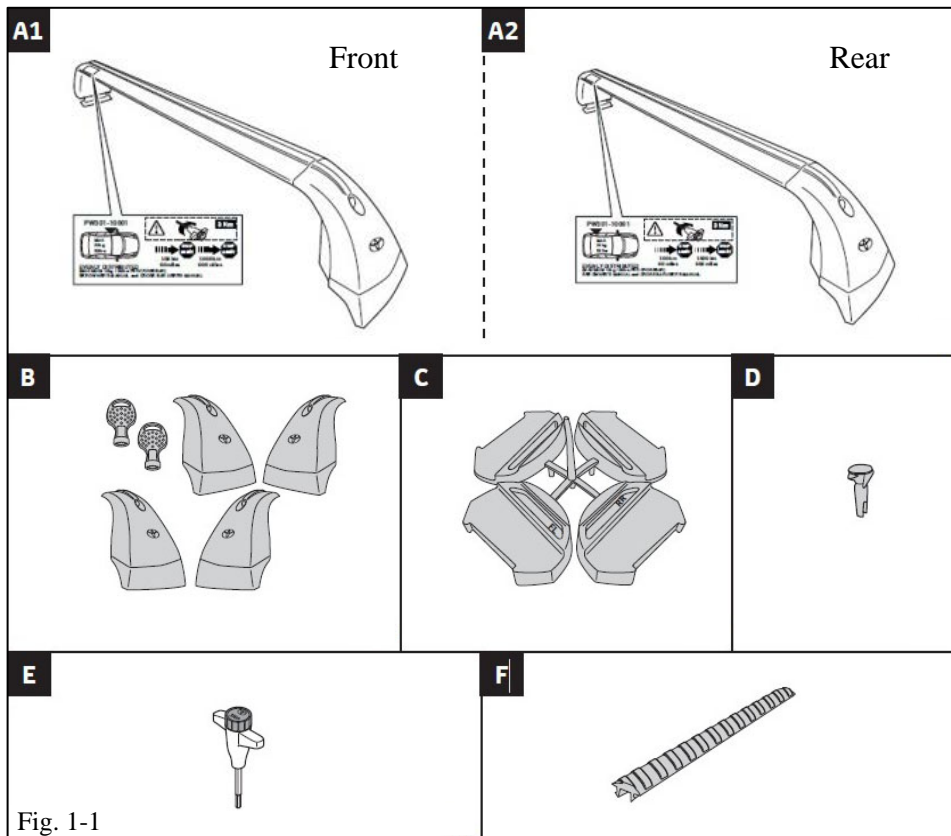
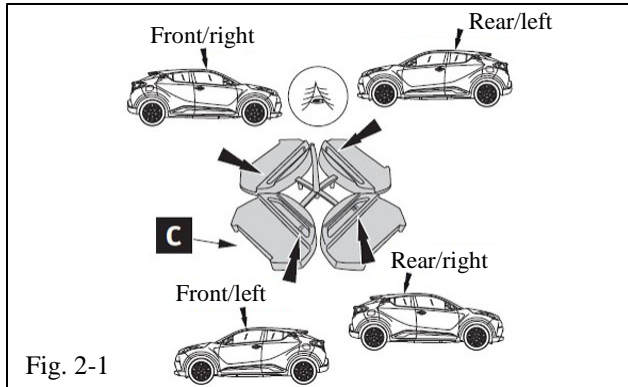

Fig. 1-1

2. Prepare to Install the Cross Bars.

- (a) Locate the rubber pads (item C) and detach them from the excess material (Fig. 2-1).
- (b) Protect the roof with a blanket.



- (c) Identify where on the vehicle each cross-bar foot will mount. Labels on the inside of the left side indicate the vehicle position, front or rear (Fig. 2-2).
- (d) Using the end cover key (item D), remove all four end covers (item D) and set aside.

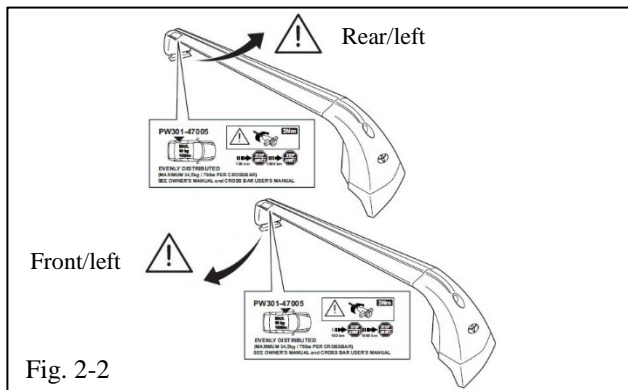

- (e) Install the rubber pads (item C) onto the bottom of the appropriate cross bar support. Each pad is marked with its location (Fig. 2-3).

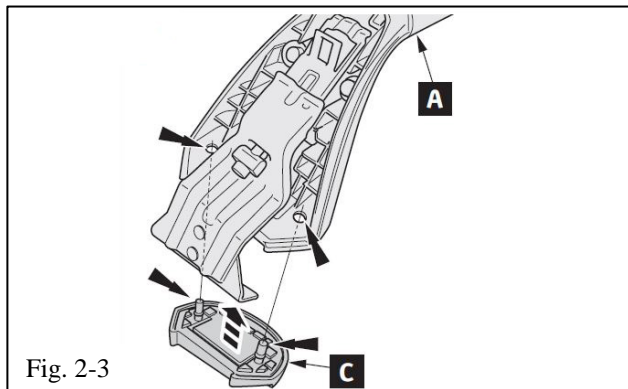

- (f) Pull up on the rubber tabs to fully seat the pad (Fig. 2-4).

**⚠ NOTE:** Use pliers to pull the rubber taps to fully seat the pad if necessary.

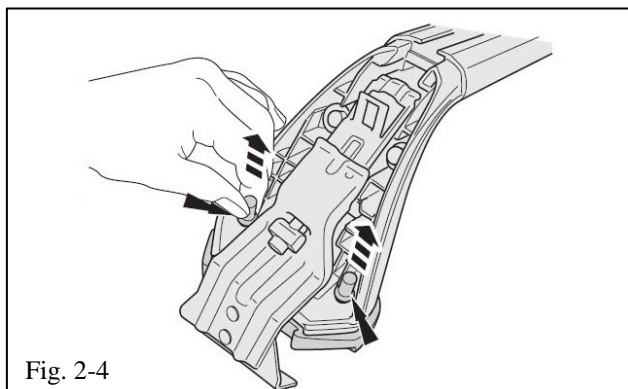

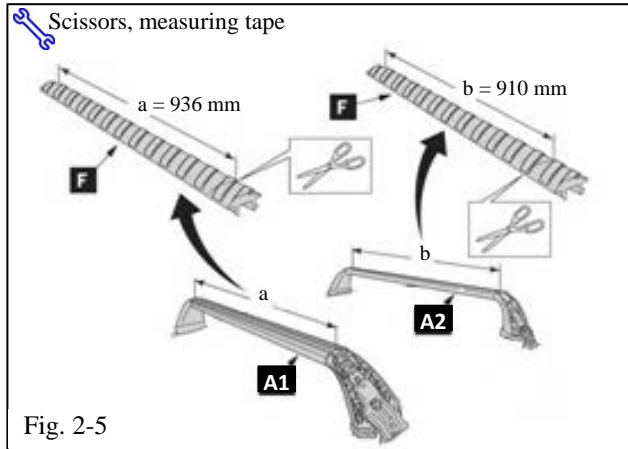

Fig. 2-5

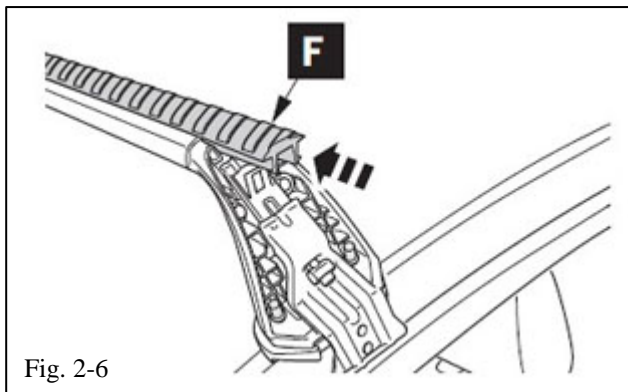

Fig. 2-6

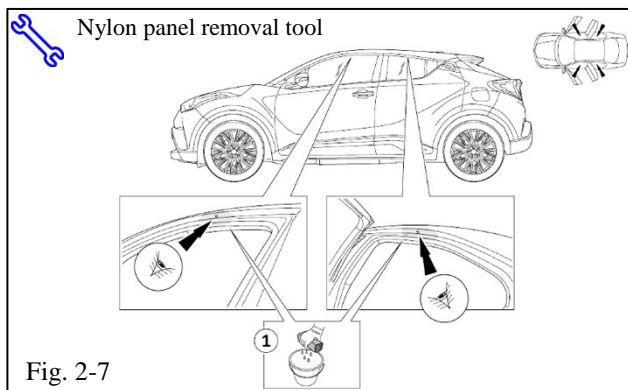

Fig. 2-7

(g) Cut the rubber inserts (item F) to match the length of each cross bar, and slide them into position (Fig. 2-5 & Fig. 2-6).

**⚠ NOTE:** Use a workbench.

(h) Open all four doors and clean the indicated mounting area with VDC-approved cleaner or soap and water solution (Fig. 2-7).

(i) Use a nylon panel removal tool to remove the 4 caps and discard them (Fig. 2-7).

**⚠** (j) Using scissors, neatly cut open the plastic bag containing the installation torque tool (item E) and the resealable bag of plastic inserts (item D).

(k) Remove the 4 plastic inserts (item D) from the resealable plastic bag.

(l) Retain the non-resealable bag for storage of the installation torque tool and keys.

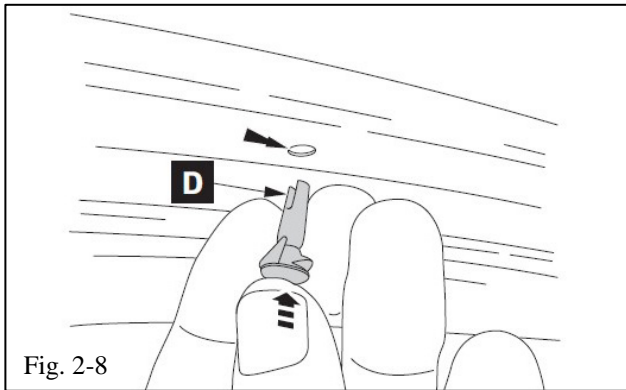

Fig. 2-8

(m) Install the 4 plastic inserts (item D) into each hole at the top of the door frame (Fig. 2-8).

- ⚠ (n) Use the provided installation torque tool (item E) to loosen the clamp assemblies on the cross bars enough to allow for installation. The clamp fastener will come off if loosened all the way.

### 3. Install the Front and Rear Cross Bars

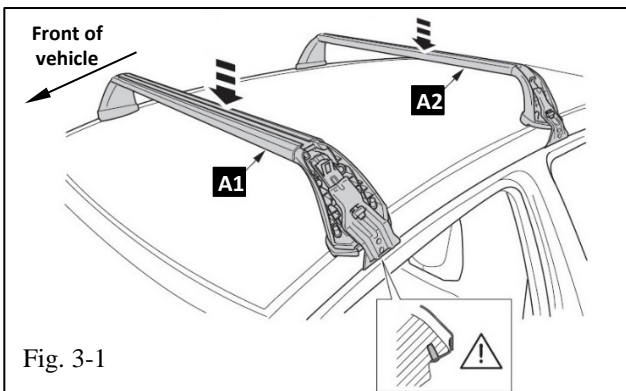

Fig. 3-1

(a) Carefully place the front cross bar (item A1) where the pins are aligned with the front mounting holes (Fig. 3-1).

- ⚠ **NOTE:** Do not move or slide the cross bar along the vehicle body.

(b) Carefully place the rear cross bar (item A2) where the pins are aligned with the rear mounting holes (Fig. 3-1).

- ⚠ **NOTE:** Do not move or slide the cross bar along the vehicle body.

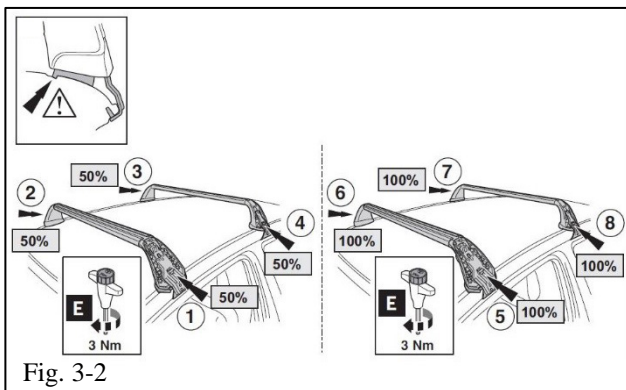
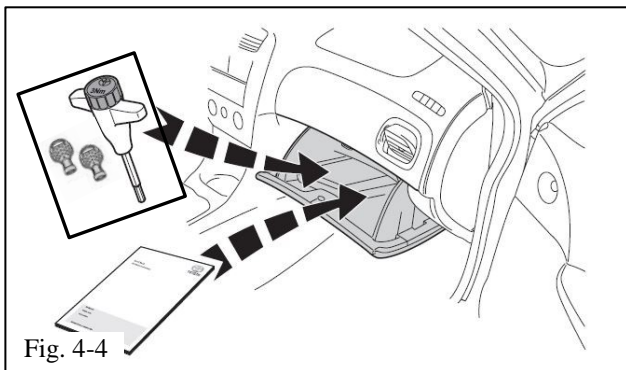
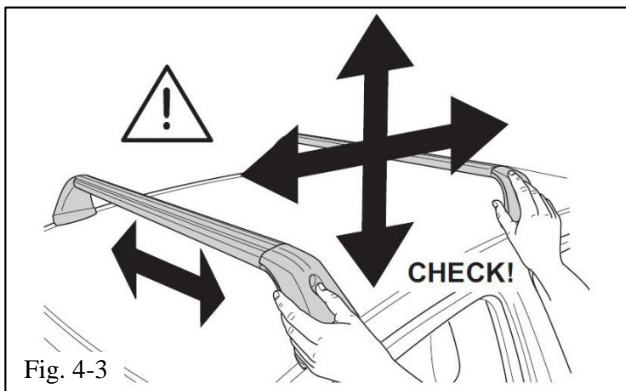
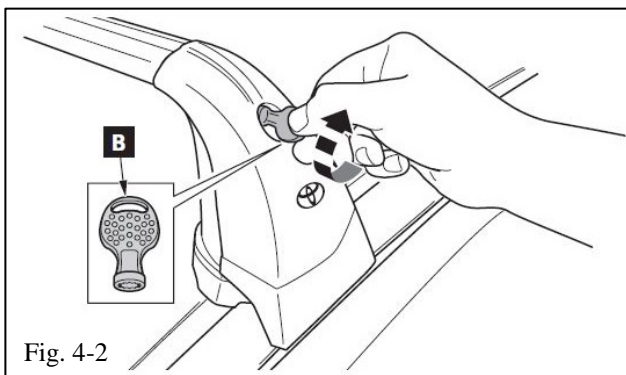
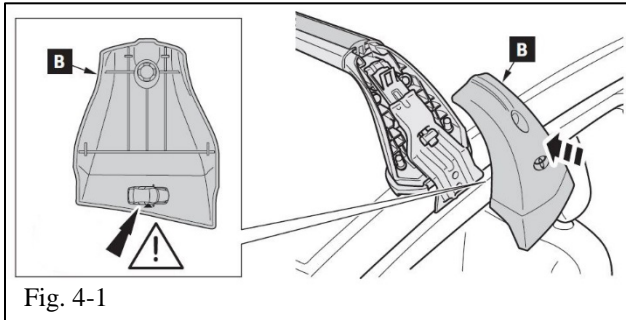

Fig. 3-2

(c) Use one hand to fully seat the locating pin into the holes in the door frame, then use the provided installation torque tool (item E) to partially tighten (about 50%) each support.

- ⚠ **NOTE:** Ensure that the cross-bar supports are placed properly onto the roof by making sure the rubber pad is fitted in the drip rail and the locating pins are fully seated into the holes in the door frame (Inset, Fig. 3-2).

(d) Tighten each support until the installation torque tool (item E) clicks (100%) (Fig. 3-2).



#### 4. Complete the Installation.

- (a) Install the covers (item B) onto each support. Each cover has its location shown on the inside surface (Fig. 4-1).

-  (a) Use one of the keys (item B) to lock the covers into position by turning the key clockwise approximately 1/4 turn (Fig. 4-2).

 **NOTE:** Both keys are the same.

- (b) Remove the key (item B) and place it in the plastic bag.

- (c) Check that the cross bars are tight and do not move (Fig. 4-3).

-  (d) Place the manual and bag [with cover keys and installation tool] in the glove compartment (Fig. 4-4).



Checklist - these points **MUST** be checked to ensure a quality installation.

Check:

Look For:

Accessory Function Checks

Ensure the cross bars are secure and in correct position

  Ensure the covers are securely attached

Ensure throw-ins are in glovebox

Cross bar knobs are tight and each clamp pin is properly inserted in the door frame hole

Covers are securely in place and locked

Manual and plastic bag that contains installation torque tool and cover keys

Vehicle Function Checks

Vehicle Appearance Check

After accessory installation and removal of protective cover(s), perform a visual inspection.

Ensure no damage (including scuffs and scratches) was caused during the installation process.

(For PPO installations, refer to TMS Accessory Quality Shipping Standard.)